

Advantages of "Full-lift type" vent technology

Introduction

Low pressure safety relief valves are highly sensitive devices, which have to fulfill nearly the same requirements as conventional safety valves with regard to safety and set pressure tolerance. This is particularly required if they are incorporated into a closed control loop. Tightness up to set pressure, minimum set pressure tolerance, minimum pressure increase after start open until full open, which means top performance.

Low pressure vents cover a set pressure range starting at 2 mbar (0.79" wc) up to approx.

200 mbar (2.9 psi), conventional safety valves are designed for pressure higher than 0.2 bar (79" wc) as per ISO standard. Even low pressure vents must be able to achieve a leakage rate according to DIN 3230, test procedure B0.

Leakage rate 3 represents the minimum standard. In order to reduce emissions, especially nitrogen losses, vents have to comply with leakage rate 2 or even leakage rate 1, if this can be realized economically. The PROTEGO® low pressure vents have up to ten times lower leakage rates (up to 50 times lower for 8" sizes and larger) as required

by API (American Petroleum Institute) and EPA (Environmental Protection Agency) standards and are state of the art technology.

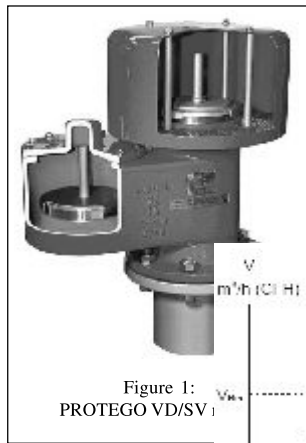

Figure 1: PROTEGO VD/SV1

arresters.

Since 1985, PROTEGO® has improved many aspects of its vent technology. Today, PROTEGO® is well known worldwide for its high quality and tailor made solutions.

Technical Advantages of Vents

Global companies are now strongly focusing on emission reduction for

The PROTEGO® business focus is mainly directed towards low

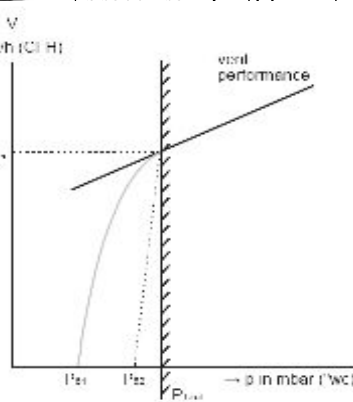

meeting environmental requirements according to EPA regulations.

This emission reduction or vapor loss prevention and nitrogen blanketing gas reduction results in capitals savings. But how to achieve it?

Looking into the general performance diagram figure 2: The set pressure $p_o = p_{o1}$ should be as close as possible to the max. allowable tank pressure p_{Tzul} to realize a better and wider range in the tank. At this new set $p_o = p_{o2}$ the performance (rate) shall be additionally by an optimized design of the (ure 2). The better the design ing, the higher the volume

these goals, a new series of on vents have been

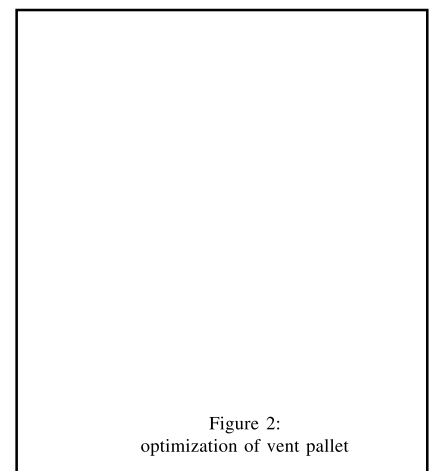
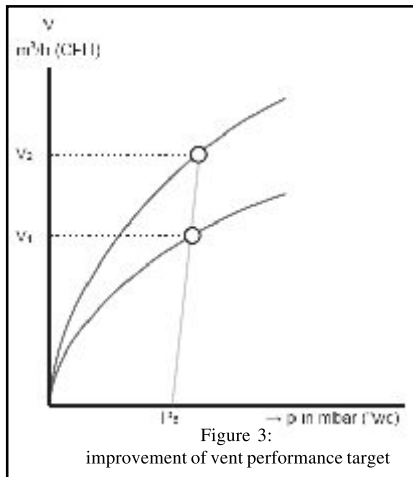

Figure 2: optimization of vent pallet

SPECIAL FEATURE

developed, which only require 10% overpressure above the pressure set point to reach full performance. Flat standard discs were developed further up to full lift disc vent pallets having a design similar to those of safety valves. This means that the set pressures closer to the **Maximum Allowable Working Pressure (MAWP)** can be used.

For small flow rates a flat standard disc



vent has an operating range, which is more or less unstable. The vent pallet operation of those vents, which are permanently working in the low pressure range, is the real problem: The pallet flutters or hammers. The solution of the problem was a type of vent pallet which releases the complete cross section due to full lift immediately after opening.

Actually, full lift pallets are nothing new. Nevertheless, correct sizing of the rim and the relation between vent seat diameter and the height, rim angle and diameter of the rim as well as a sophisticated technique to produce the rim without waviness of the pallet are the fundamental factors that influence the vent performance, especially for low set pressures.

Moreover, fluttering in the unstable range is prevented by proper

adjustment of lift stop. The vent opening pressure can be selected very close to the maximum allowable tank pressure.

The idealized pressure increase until full open is nearly zero. Reproducible and lower leakage is achieved either by metallic sealing or at low pressure settings supported by air cushioned

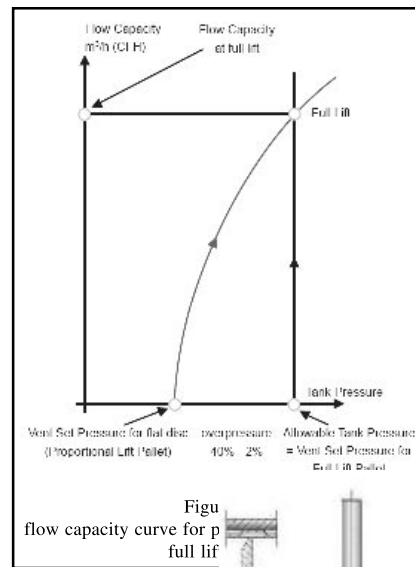

FEP (Teflon-) gaske disc (figure 4). The imprint of the crimp texture free metal surface on the high polished FEP-surface assure an impressive result.

The flow capacity curve for the vent equipped with the flat disc (=proportional lift pallet) on the one hand and the full lift type disc on the other hand is shown in figure 5. The characteristic shows pressure vs. volume flow.

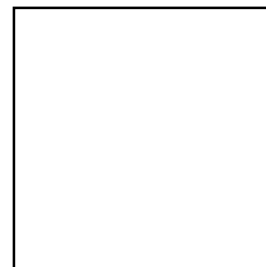

The pressure increase for the full lift type vent at the

design flow rate is nearly zero from start of opening until full lift, in contrast to the 40% pressure increase allowed - as a maximum - by DIN 4119 or even 100% by API. The advantage is using nearly the complete pressure range up to the tank design pressure for vents with real full lift.

This is an advantage for the environment, because the vents start to open later and are therefore closed longer, which also reduces losses of blanketing gas, inerting gas or direct product losses.

According to API 2000 the typical overpressure rating of weight loaded conservation vents is 80% - 100%. Knowing that higher set pressures can reduce emission and vapor losses significantly (VDI 3479 Guideline), the full lift type technology vent pallet (10% overpressure rating) is a beneficial asset to increase set pressure close to the MAWP.

Figure 6 shows the vapor saving potential of a tank farm for a 100%, 40%, 10% and a theoretical 0% overpressure vent rating. These calculations are based on the VDI 3479 Guideline. The figure shows that compared to no pressure holding device (freely vented tank), a 100% pallet achieves a vapor saving of roughly 36%. A 40% pallet achieves a vapor saving of about 51% and a 10% pallet saves an additional 14%. The theoretical value of a 0% pallet would increase the vapor saving by another 6.5%. Replacing 100% vent technology by 10% full lift technology can reduce vapor losses up to 30%.

PROTEGO® vents have an overpressure rating as small as 3% - 6% depending on size and construction of

SPECIAL FEATURE

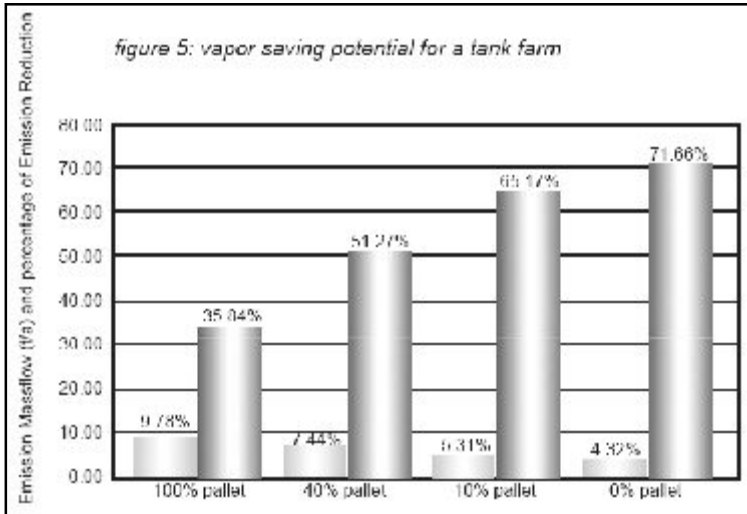

the devices, for this reason we included the 0% pallet as an example. For safety reasons we do recommend to use the

table 1: admissible leakage rates according to the normal PROTEGO® standard, but also lower leakage rates are available (based on the PROTEGO® Quality Standard)

nominal width DN	admissible leakage rate		test time
	[m³/a]	[m³/min]	
40	18	1.8	1
100	27	8.1	2
150	36	10.8	2
200	45	13.5	2
250	54	16.2	2
300	63	18.9	2
350	72	21.6	2
400	80	24.0	2

table 2: test pressures as a function of the adjusted set pressure for measuring the admissible leakage rates

Adjusted set pressure	Test pressure as percentage of adjusted set pressure
5 (2.0)	75
10 (3.94)	90
20 (7.87)	90

10% rating for design purposes.

Higher set pressures and lower leakage rates have a direct impact on complying with EPA requirements.

PROTEGO® offers devices for pressure settings lower than 5 mbar (2.0 “wc) that have an extremely low leakage rate for FEP to metal sealing. The leakage rates depend on the size of the device (table 1). Depending on the set pressure the leakage rates are measured at a test

pressure 75%,

80%, 85% and 90% of the set pressure (table 2). In addition to the previously mentioned vent standards, the full lift

type pallet technology has advantages in nitrogen blanketing applications (figure 6). For example, in the USA typical set pressures of nitrogen blanketing regulators are 1.8 mbar (0.72”wc) and the MAWP of the tank is 5 mbar (2.0”wc) and 100% overpressure pallet has to be set at 2.5 mbar (1.0”wc). Considering the blow down, the vent closes below 1.8 mbar (0.72”wc), therefore the pallet floats if the nitrogen regulator has opened once. This results in expensive losses of nitrogen. With the full lift type technology the vent can be set higher and reseats above the nitrogen regulator set pressure. In this way nitrogen losses are reduced and vapors are saved. A blow down of 0%, like mentioned in API 2000, table C-1 (operating characteristics of venting

devices), is only a theoretical value and can never be achieved in reality.

Conclusion

To fulfill the demands of the German clean air act, PROTEGO® had to develop state of the art vent technology, with improved sealing capabilities and vapor reduction potential by also increasing the application range of the devices.

The goal was met through vents which need only 10% overpressure before reaching full flow performance. With the presented vent technology, plant venting installations are beneficially improved by saving vapor and nitrogen losses. Furthermore, low leakage rates achieved through accurate manufacturing and quality control help to meet more stringent EPA requirements.

An additional design advantage of the “full lift type“ technology is the higher flexibility in setting the vent closer to the set pressure of the emergency relief vents without forcing these into the chattering zone. It is our recommendation to achieve full performance from a conservation vent 10% to 20% below the set pressure of the emergency relief vent.

Considering the best available practice

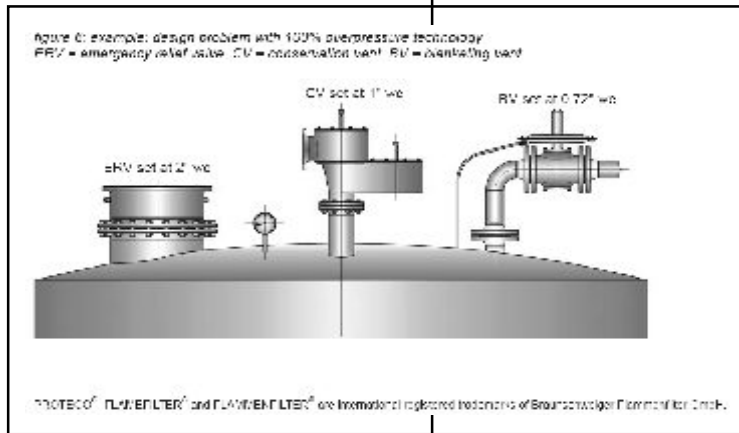

ensures safe operation for the benefit of the environment and in addition reduces financial losses.